



Extend Equipment Life

Minimize Maintenance Costs

Maximize Up-time

Improve Efficiency



One less **Fire** to handle.

“ Those companies that repair their equipment primarily on a fire-fighting basis pay a high price in lost productivity, service and quality.”

“The most cost-effective approach to plant asset management is to move to a more planned environment”

Plant Services magazine, January 1999

Maintenance Agreement

An experienced Air Mac mechanic, trained in Compactors, Balers, Shredders, Pre-Crushers, and troubleshooting performs a twenty point check on critical systems.

A complete report of their findings is left with the customer detailing operating readings such as amperage, pressures and various temperatures. All preventive maintenance performed is documented.

PM CHECK LIST	Checked	Service	Notes
1. AIR TO TEST			
2. LUBRICANT LEVEL			
3. HYDRAULIC OIL			
4. ELECTRICAL SYSTEM			
5. TRACKS/DRUMS			
6. DRIVE SHAFTS			
7. BELT DRIVES			
8. PULLEY SYSTEMS			
9. HOIST SYSTEMS			
10. SAFETY DEVICES			
11. OVERLOAD PROTECTORS			
12. THERMAL PROTECTORS			
13. PRESSURE CONTROLS			
14. TEMPERATURE CONTROLS			
15. VIBRATION MONITORS			
16. NOISE MONITORS			
17. AIR QUALITY MONITORS			
18. OIL ANALYSIS			
19. WELDING POINTS			
20. STRUCTURAL INTEGRITY			

PM Report Records Work Done

Balers, Compactors, Shredders, Precrushers

ALL Major Brands Serviced

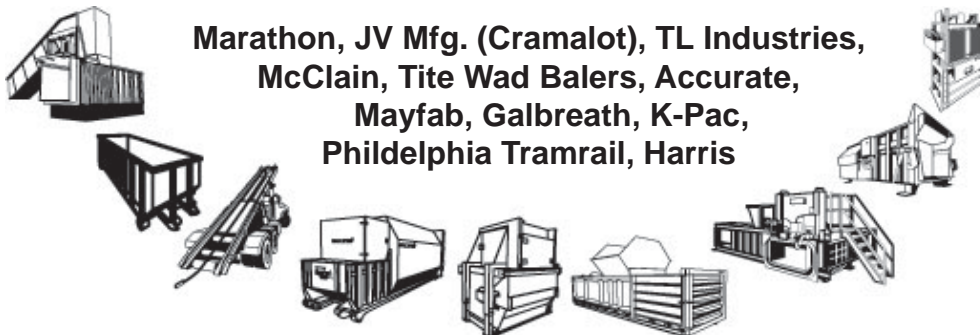

Marathon, JV Mfg. (Cramalot), TL Industries, McClain, Tite Wad Balers, Accurate, Mayfab, Galbreath, K-Pac, Philadelphia Tramrail, Harris

Balers, Compactors, Shredders, Precrushers

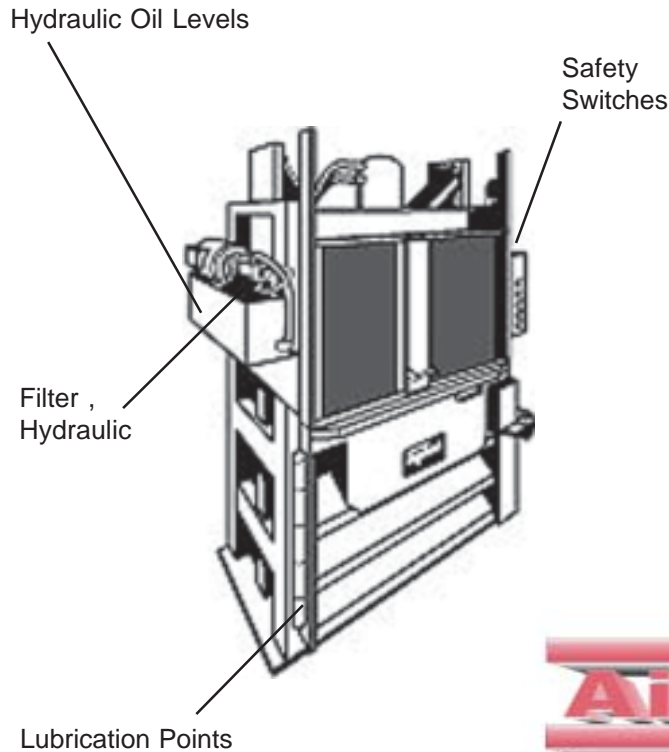
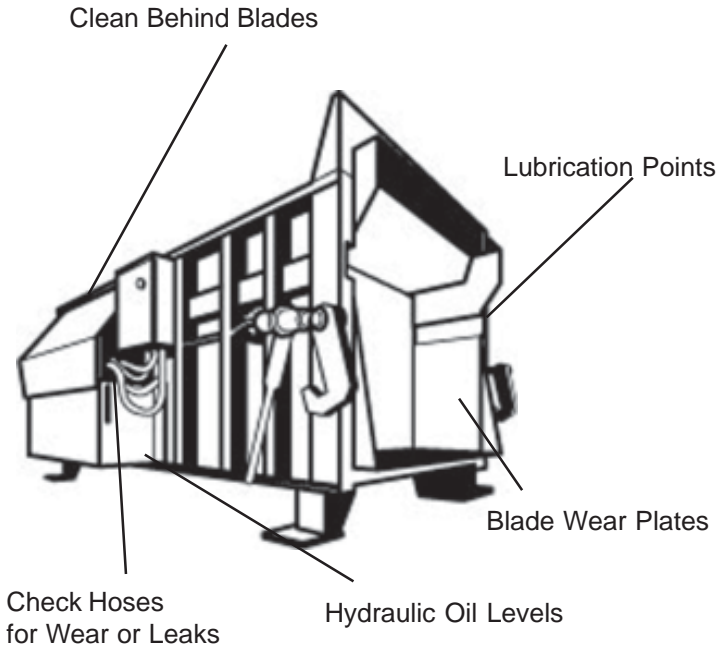

What is a maintenance agreement?

A simple agreement between you and Air Mac to perform scheduled preventive service on a regular basis. Air Mac is responsible for keeping track of required preventive service, and contacting you for scheduling when needed.

What work needs to be done?

Clean-out behind the blade, check safety devices. Inspect or replace Hydraulic fluid and filter. Verify controls operation, look for leaks, inspect hoses, pumps and fittings.

Why choose Air Mac?

We have built our business satisfying customers' service needs, it's our specialty. Safety trained experienced personnel have a large inventory of replacement parts available for all major brands. *A documented service history is kept on each piece of equipment.* Preventive maintenance is scheduled and controlled by our Computerized Maintenance Management System (CMMS)

When is preventive maintenance needed?

Compactors and Balers require regular service. Frequency of service is dictated by equipment age, general state of repair and the amount of use (operating hours). We analyze your site conditions and meet with you to discuss a program tailor-made for your specific needs.



8901 Directors Row

Dallas, TX 75247

ph(214)879-1010 fax(214)879-1011

www.airmac.com

1104 S.E. 59th

Oklahoma City, OK 73129

ph(405)632-2510 fax(405)632-0023