

Maintenance Agreement

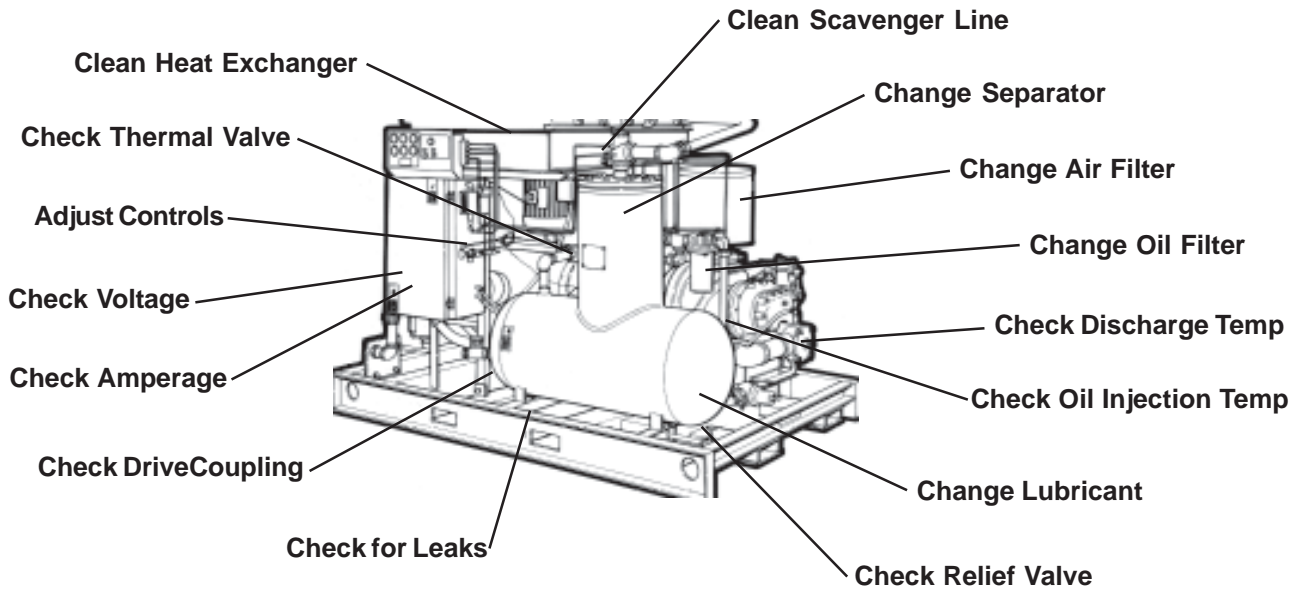

What is a maintenance agreement?

A simple arrangement between you and Air Mac to perform scheduled preventive service on a regular basis. Air Mac is responsible for keeping track of required preventive service, and contacting you for scheduling when needed.

What work needs to be done?

Controls cleaned and adjusted, safety devices checked, lubricant filter, air filter, separator element and lubricant need to be changed and heat exchangers require cleaning.

Why choose Air Mac?

Quality is our focus. We have built our business satisfying customers rotary air compressor service needs, it's our specialty. Safety trained experienced personnel have a large inventory of replacement parts available for all major brands. A documented service history is kept on each piece of equipment. Preventive maintenance is scheduled and controlled by our Computerized Maintenance Management System (CMMS)

When is preventive maintenance needed?

Rotary screw air compressors require regular service. This can be as often as quarterly, or as infrequently as once a year. Frequency of service is dictated by inlet air quality, ambient temperature, equipment age, type of lubricant used and operating hours. We analyze your site conditions and meet with you to discuss a program tailor made for your specific needs.



8901 Directors Row
Dallas, TX 75247

ph(214)879-1010 fax(214)879-1011

www.airmac.com

1104 S.E. 59th
Oklahoma City, OK 73129

ph(405)632-2510 fax(405)632-0023